



BIRFIELD RING INSTALLATION INSTRUCTIONS

Introduction:

Thank you for purchasing our birfield rings. The rings are intended to add strength to one of the weakest links known to Samurai wheelers, the birfield joint. The design utilizes available space in the knuckle assembly to increase the wall thickness of the birfield outer race. You will notice that the rings seem rather simple. That's our sentiments exactly. We think we created a simple fix to a very serious problem.

Many people ask about the cost of the rings, which is always a concern to customers. We assure you that you are getting the most for your money and we feel very comfortable explaining this to our customers. Here it goes. To begin, space was limited. We had to work with the highest quality material to get the strength requirements needed. Next, the material is properly heat treated to get the ideal hardness for this application. The press fit of the ring on the birfield joint is critical to ensure maximum performance. An incorrect press fit is like putting a rubberband on the birfield joint. Each ring is held to a very tight tolerance on the I.D. (± 0.005 "). This tolerance is checked with a Coordinate Measuring Machine (CMM) and we guarantee each ring out the door holds this extremely tight tolerance.

Special Tools Needed:

Die grinder
Hydraulic Press
Suzuki Service Manual (recommended)

Front Axle Removal:

- 1) Loosen front wheel nuts, raise and support front axle on stands. Remove wheels.
- 2) Drain front differential oil.
- 3) Remove disc brake caliper with carrier.
- 4) Remove tie rod ends from both steering knuckles. A tie rod end remover is recommended.
- 5) Mark hub cover to hub body to ensure proper re-assembly. Remove hub cover (6 bolts).

- 6) Remove circlip on the end of the axle shaft (inside hub).
- 7) Remove the 8 bolts securing the oil seal cover from back of steering knuckle. Remove steel retainer, felt pad, and oil seal.
- 8) Remove top and bottom kingpins (4 bolts securing each). Be sure to mark them top and bottom. Do not switch the kingpins around.
- 9) Pull off steering knuckle complete with spindle, hub, and rotor. Axle shaft should remain in axle housing.
- 10) Place kingpin bearings aside. Mark the original locations for the bearings. Do not switch these around either.
- 11) Remove both axle shafts from housing.
- 12) The following areas need to be cleaned for the rest of the installation: front axle birfield joints (outer surface where press fit is taking place), part of axle housing where birfield joint resides (area where grinding will take place).

Birfield Ring Press Fit:

- 1) Double check to make sure the inside of the birfield rings and the outside of the birfield joints are free of debris (these will be the mating surfaces).
- 2) Lubricate the mating surfaces with grease.
- 3) Take notice of the direction in which the birfield ring is to be pressed onto the birfield joint. The step inside the ring is to fit over the ridge on the birfield joint.
- 4) Set up the birfield ring with the birfield joint on a hydraulic press as shown in Figure 1. Please do not attempt to hammer the rings in place. The rings carry a precision force fit which directly effect their performance.

FIGURE 1

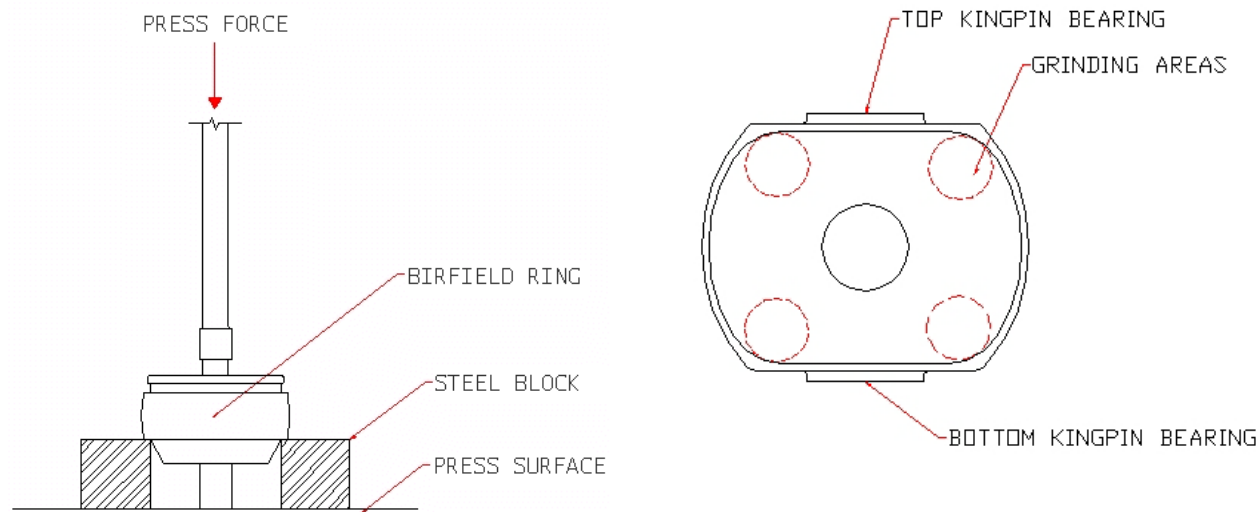

- 5) Press the rings on until they bottom out on the birfield joint. Back surfaces will be flush when complete.

Material Removal of Inner Axle Housing:

Note: This material removal is necessary to maximize the size of the birfield ring. This will not decrease the integrity of the axle housing so no need to worry. However, this small amount of material removal does allow for a much stronger product.

- 1) Stuff a rag into front axle seals to prevent grinding dust from entering axle tubes.
- 2) To find the grinding areas, read this carefully to identify them. The inner knuckle is a forged piece. There are two machined surfaces inside this inner knuckle where the bearing races seat. You can distinguish these machined surfaces by identifying the tool marks that make up this area. Where this machined surface meets the forged surface, a ridge is formed. You can feel this ridge to the left and right of the bearing races by running your finger over it. Using a die grinder, remove approximately 1/16" of material in the areas from the highest point of the ridge, shown in Figure 2, to provide clearance for the birfield ring. You should feel a smooth transition from the forged to the machined surfaces after material is removed. In addition, remove approximately 1/16" from the center of the step in the lower region to provide clearance for the birfield when turned.

FIGURE 2 <CONT>

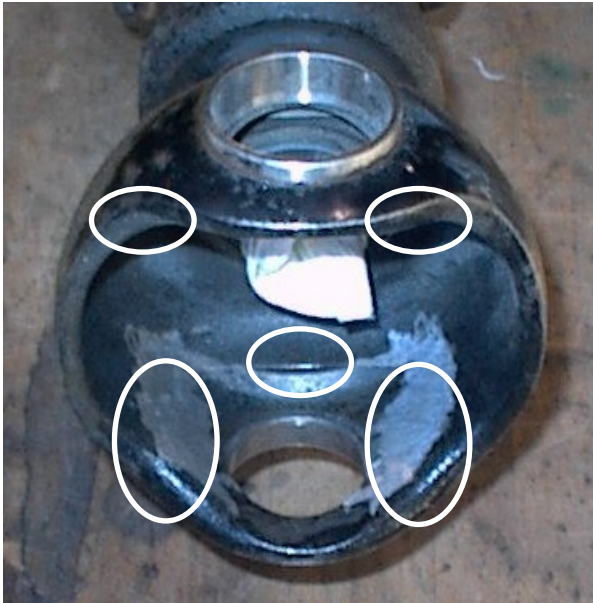

3) When you feel you have provided enough room for the new birfield rings, you should do the following quick test to check for proper clearance. First, wipe off any debris inside the axle housing. Then, slide the axle shaft complete with birfield ring inside axle housing. Line up wear mark on the sealing surface of the shaft with the axle seal (where the axle would sit if fully assembled). Turn the outer portion of shaft about its turning axis (line connecting top and bottom kingpins). While turning, check to make sure the birfield ring does not touch the inside of the housing. If so, regrind the areas of contact.

4) Once you feel confident in the above test with the axles in place, temporarily assemble the knuckles to the housing with the kingpins. Turn the knuckle while spinning the hub to check for binding. If binding occurs, disassemble and regrind the areas of suspected contact. (If you are having difficulty reassembling the knuckle and kingpins to the housing, there is a little trick involved with the birfield rings. In the Front Axle Assembly below, skip to step 5 for the details, however, adding bearing grease is not necessary).

Front Axle Assembly:

Please make note that assembly with the birfield rings will be slightly different then the normal assembly. Read this section carefully so no problems are encountered.

- 1) Make sure that all front axle components are free of grinding dust and other debris.
- 2) Pack the housing ends with fresh axle grease.
- 3) Pack the back of the birfield joint with fresh axle grease.
- 4) Slide axle shaft into housing.
- 5) Pack kingpin bearings with fresh axle grease and put the top bearing in place first. Do not put in the lower bearing yet.
- 6) Make sure the felt pad and knuckle seal are both in place over the housing.
- 7) Slide complete knuckle assembly with hub, spindle, and rotor onto the axle shaft and housing.
- 8) Pitch the knuckle upward to allow the lower kingpin bearing to be installed into its race.
- 9) Install kingpins and secure kingpin bolts.
- 10) Secure the knuckle seal, felt pad, and steel retainer plate with the 8 bolts.
- 11) Install circlip onto axle (located inside hub). If axle shaft is not sticking out enough to get the clip in its groove, an 8mm bolt can be threaded into the shaft to pull it out as needed.
- 12) Install hub cover with the 6 bolts. Make sure the cover is aligned using the marks made during the Front Axle Removal, step 5.
- 13) Install tie rods.
- 14) Mount the brake calipers.
- 15) Mount wheels and lower vehicle. When the vehicle is lowered, make sure the wheel lugs are tight.

SPIDERTRAX INC
7510 Hygiene Rd.
Longmont, CO 80503

Phone: 303-772-0033
Email: tech@spidertrax.com